

LA-CoNGA physics Introduction to Measurements Systems Digital vs Analog

by Dennis Cazar Ramírez

February 18, 2023



- Digital vs Analog quantities [an overview](#)
- Digital to Analog Conversion *DAC*
- *DAC* Characteristics
- Analog to Digital Conversion *ADC*
- *ADC* Characteristics

Digital vs Analog

- **A digital quantity** can assume only a discrete numbers of symbols called "digits", i.e. binary, decimal, hexadecimal.
- In the binary system, a digit is represented as a voltage that may actually have a value that is anywhere within specified ranges
- For example, for the *Arduino* logic:

$$0V \text{ to } 0.5V = "0"$$

$$2V \text{ to } 3.5V = "1"$$

- By contrast, **an analog quantity** can take on any value over a continuous range of values, its exact value is significant.
- [differences between analog and digital](#)

Digital vs Analog

- Most physical variables are analog in nature and can take on any value within a continuous range of values. Examples include:
 - temperature, pressure
 - light intensity, audio signals
 - position, rotational speed, and flow rate.

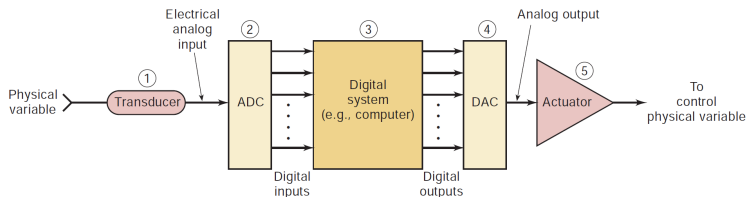

- Analog-to-digital converter (ADC) and digital-to-analog converter (DAC) are used to interface a computer to the analog world so that the computer can monitor and control a physical variable

- **Analog-to-digital converter (ADC)**. The ADC converts an analog input to a digital output. This digital output consists of a number of bits that represent the value of the analog input



- **Digital-to-analog converter (DAC)**. This digital output from the computer is connected to a digital-to-analog converter (DAC), which converts it to a proportional analog voltage or current

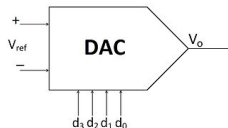

Digital to Analog Conversion

4-bit DAC

- D/A conversion is the process of taking a value represented in digital code (such as straight binary or BCD) and converting it to a voltage or current that is **proportional to the digital value**

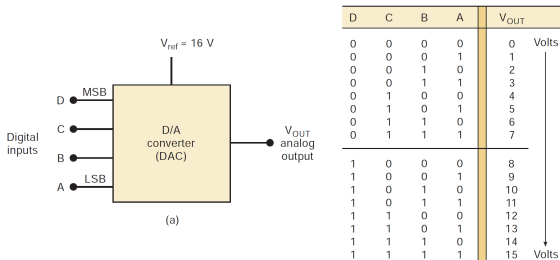

- Notice that there is an input for a **voltage reference**, V_{ref} . This input is used to determine the **full-scale output** or maximum value that the D/A converter can produce

Digital to Analog Conversion

4-bit DAC

- The analog output is proportional to the digital input

$$\text{Analog Output} = K \times \text{Digital Input}$$

- where K is the proportionality factor and is a constant value for a given DAC connected to a fixed reference voltage
- In this example:

$$V_{out} = (1V) \times \text{Digital In}$$

- A five-bit DAC has a current output. For a digital input of 10100 , an output current of 10 mA is produced. What will I_{out} be for a digital input of 11101 ?
- What is the largest value of output voltage from an 8-bit DAC that produces 1.0 V for a digital input of 00110010 ?

Digital to Analog Conversion

Characteristics

- **Analog Output** The output of a DAC is technically not an analog quantity because it can take on only specific values
- However, the number of different possible output values can be increased and the difference between successive values decreased by increasing the number of input bits

D	C	B	A		V_{OUT} (V)
0	0	0	1	→	1
0	0	1	0	→	2
0	1	0	0	→	4
1	0	0	0	→	8

- **Input Weights** note that each digital input contributes a different amount to the analog output. This is easily seen if we examine the cases where only one input is *HIGH*

Digital to Analog Conversion

Resolution

- **Resolution** of a DAC is defined as the smallest change that can occur in the analog output as a result of a change in the digital input. It is always equal to the weight of the *LSB* and is also referred to as the **step size**

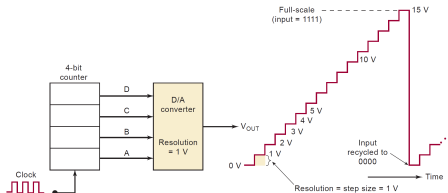

- Note that the staircase has 16 levels corresponding to the 16 input states, but there are only 15 steps or jumps between the 0-V level and full-scale. For an N -bit DAC the number of different levels will be 2^N , and the number of steps will be $2^N - 1$

Digital to Analog Conversion

Resolution

- You may have already figured out that **resolution** (step size) is the same as the **proportionality factor** K in the DAC input/output relationship:

$$\text{resolution} = K = \frac{A_{fs}}{2^N - 1}$$

- where A_{fs} is the *analog full-scale output* and N is the *number of bits*.
- **Percentage Resolution** It is also useful to express it as a percentage of the full-scale output

$$\% \text{ resolution} = \frac{K}{A_{fs}} \times 100$$

- A *10-bit DAC* has a step size of *10 mV*. Determine the full-scale output voltage and the percentage resolution.

DAC circuitry

Basic circuit

- A 4-bit DAC circuitry. The inputs are assumed to have values of either 0 or 5 V. An op-amp is employed as a *summing amplifier*

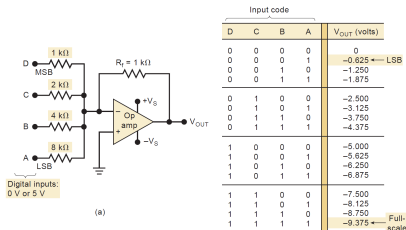

- Recall that the *summing amplifier* multiplies each input voltage by the ratio of the feedback resistor R_F to the corresponding input resistor R_{IN}

$$V_{OUT} = -(V_D + \frac{1}{2}V_C + \frac{1}{4}V_B + \frac{1}{8}V_A)$$

Analog to Digital Conversion

ADC

- An analog-to-digital converter takes an analog input voltage and, after a **certain amount of time**, produces a digital output code that represents the analog input.
- The A-D conversion process is generally more complex and time consuming than the D-A process

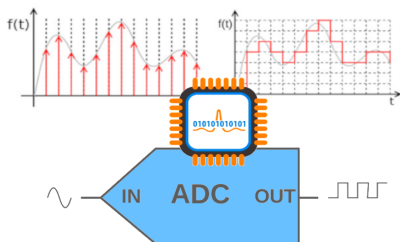

- An *ADC* circuit is more complex compared to a DAC

Analog to Digital Conversion

Basic Circuit

- Several important types of ADCs utilize a DAC as part of their circuitry.
- Figure below is a general block diagram for this class of ADC

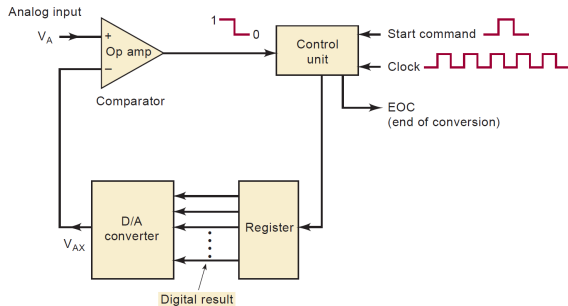

- The op-amp comparator has two analog inputs and a digital output that switches states, depending on which analog input is greater

Analog to Digital Conversion

Digital-Ramp ADC

- One of the simplest versions of the general ADC uses a binary counter as the register and allows the clock to increment the counter one step at a time until

$$V_{AX} \geq V_A$$

- It is called a **digital-ramp ADC** because the waveform at V_{AX} is a step-by-step ramp (actually a staircase)
- A digital-ramp ADC contains:
 - a counter
 - a DAC
 - an analog comparator
 - a control AND gate

Analog to Digital Conversion

Digital-Ramp ADC

- A *START* pulse is applied to reset the counter to 0. The *HIGH* at *START* also inhibits clock pulses from passing through the AND gate into the counter.

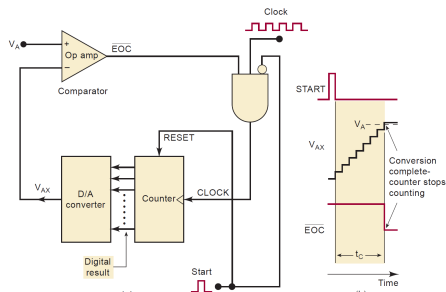

- When conversion process is complete, a \overline{EOC} is generated and the contents of the counter are the digital representation of V_A .

- **Conversion time** t_c : is the time interval between the end of the *START* pulse and the activation of the output \overline{EOC}

$$t_c(max) = (2^N - 1)clock\ cycles$$

- An average conversion time is useful

$$t_c(avg) = \frac{t_c(max)}{2} \approx 2^{N-1}clock\ cycles$$

- **Resolution**: Resolution of the ADC is the same as the internal DAC
- **Quantization Error** It is a rounding error between the analog input voltage to the ADC and the output digitized value

- Digital systems and applications, Tocci, 10th Ed Chap 11
- [Arduino Basics DAC](#)