

LA-CoNGA physics Introduction to Measurements Systems Diode Circuits

by Dennis Cazar Ramírez

January 30, 2023

Contents

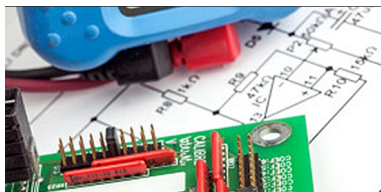

- How diode works
- Diode IV characteristics
- Types of diodes
- Diode circuits
- Exercises

Diodes

How it works

- A diode is a non-linear element, current can flow in only one direction.

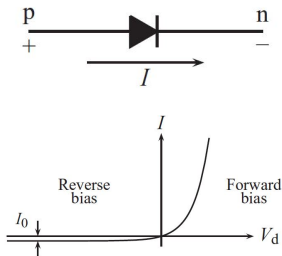

Figure: Diode schematic symbol and IV characteristic curve of a diode

- If forward biased

$$I = I_0 \left(e^{qV_d/kT} - 1 \right) \quad (1)$$

Breakdown

- Reverse biased current I_o can increase in two ways:
 - **Avalanche Breakdown** electrons have enough energy to ionize atoms and increase current.
 - **Zener breakdown** The electric field in the depletion zone is large enough to make the current increase.

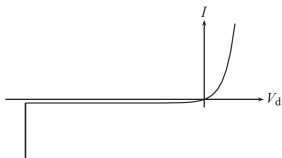
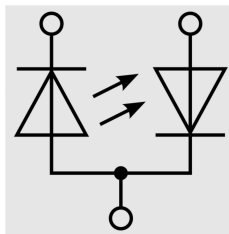

Figure: IV characteristic with breakdown

- Note that while the breakdown current increases rapidly, the voltage stays fairly constant (**breakdown voltage**).
- Despite the name, both types of breakdown are non-destructive.

Photon emission and absorption

- Another interesting effect of a diode is the possibility of producing light or changing the electrical properties of the diode through photon absorption.
- The ubiquitous Light Emitting Diode (LED) emits light when forward biased
- Photons can also be absorbed by the diode increasing the current that flows through it. This is the basis of the photo-diode, which is used in many applications as a light detector.



Basic diode circuit analysis

- The diode has an unusual I–V characteristic: it conducts readily for forward bias but does not conduct very much for reverse bias (assuming the reverse bias is less than the breakdown voltage).
- Applying KVL to this circuit we obtain:

$$V_o - IR_L - V_d = 0 \quad (2)$$

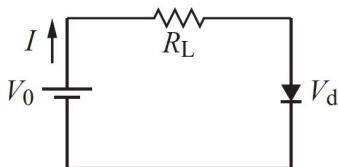

where V_d is the voltage across the diode.

Basic diode circuit analysis

- Using equation (1) we found that:

$$I = \frac{V_o - V_d}{R_L} = I_o \left(e^{qV_d/kT} - 1 \right) \quad (3)$$

- This equation cannot be solved analytically for V_d ,
- A second way is to solve the equation graphically.

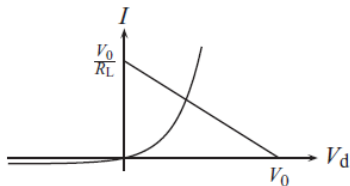

- the second is the plot of $I = (V_o - V_d)/R_L$ and is called the **load line**

Load line method

- This graphical solution is often called the **load line method** in electronics. Note that the x- and y-intercepts for the load line are V_o and V_o/R_L , respectively, and the slope of the line is $-R_L^{-1}$.

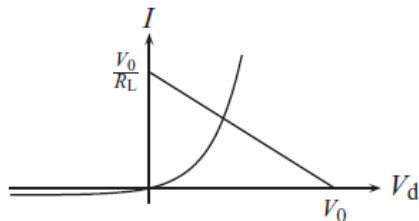

- note that the analysis is not restricted to positive V_o . If V_o is negative, the x- and y-intercepts will be on the negative portion of the x- and y-axes

Simplified model of diode

Series and parallel

- It is thus common practice to employ a **simplified model of the diode I–V** characteristic that allows for analytical solutions

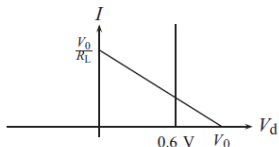
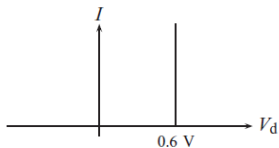

- In words: the diode will not allow current flow unless it is forward biased; when it is forward biased, the voltage drop across the diode is 0.6V.

Simplified model of diode

- Assuming the diode is forward biased, eq.(3) now yields

$$I = \frac{V_o - 0.6V}{R_L} \quad (4)$$

- how do we know at the start if the diode will be forward biased?
When $V_d > 0.6V$
- The value $0.6V$ is appropriate for diodes made from silicon, the most common material. For Germanium $V_d = 0.3V$ and $V_d = 1.2V$ for LEDs.
- What do we do if it is not? A current I_o flows.
- I_o is so small ($\approx nA$) that can be approximated as $I_o = 0$ when reverse biased

Diode applications

- Diode limiter

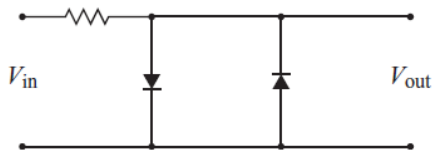

- Diode clamp

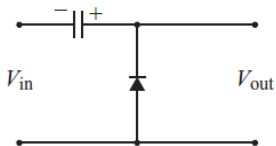

Diode applications

- Rectifier

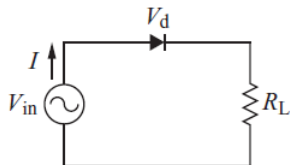

- Working at breakdown

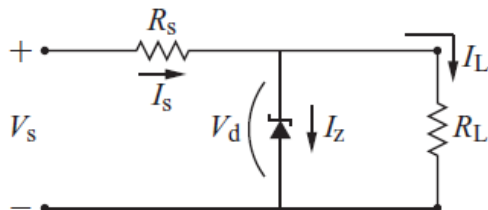

Diode Applications

- Working at breakdown

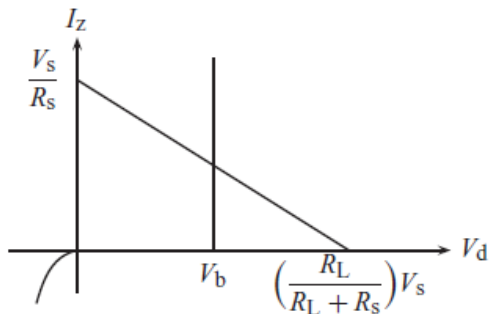

- Note that the axes are inverted

Light detection

- Avalanche photodiodes (APDs) is a highly sensitive semiconductor photodiode detector that exploits the photoelectric effect to convert light into electricity.

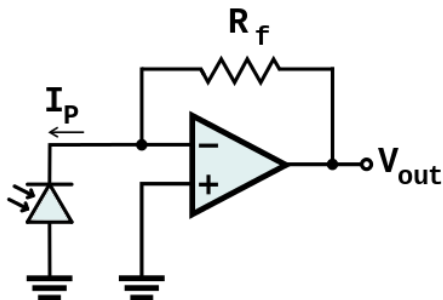

- APDs are set near to the Breakdown voltage, when light hits the APD avalanche effect occurs increasing the current in the circuit.

- Design and simulate a rectifier circuit:
 - Use a 100Hz 5V sinusoidal wave as input
 - Use a 1K resistor
 - Add a capacitor in parallel to R and vary its value (1μ , 10μ , 100μ)
 - Fix the value of C (100μ for example) and decrease the value of R to 100Ω
 - Give a qualitative explanation of your results